

General info

Technical - Systems



Ean	8021696329512
Item	STICK TRACK DOUBLE 06W
Installation	Systems
Guarantee	5 years
Gross weight	0.15 kg
Volume	0.000593 m ³

Technical info

Net weight	0.11 kg
Insulation class	III
Protection index	IP20
Compliance	CE
Operating temperature	0° ~ +40 °C
Dimmer	1, Phase-cut
Power output	48 V DC
Power supply	Required, remoted, not included Replaceable (by qualified operators only)
Accessories not included	Stick profile

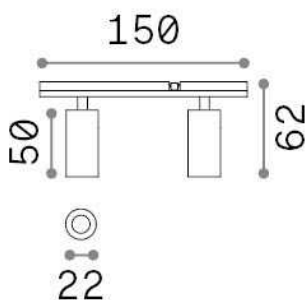

Source info

Integrated source	Integrated LED module
Replaceable source	Replaceable (by qualified operators only)
Power	6 W
Emission	Direct
Max consumption	max 6,00 W
Features LED	LED COB BRIDGELUX
CCT LED	3000 K
Duration LED (t. 25°C)	30000 h
CRI	> 90
Light beam	24°
Light beam flux	550 lm
Useful light flux	380 lm
Photobiological risk	1
Standby power	< 0.50 W